

Named Entity Linking on Handwritten Document Images

Oliver Tüselmann and Gernot A. Fink

Department of Computer Science
TU Dortmund University
Dortmund, Germany







May 23th, 2022

- ▶ Motivation
- ▶ Named Entity Linking
- ▶ Datasets
- ▶ Baseline Approach
- ▶ Results
- ▶ Conclusions

Motivation

Mr. Kennedy told Mr. Macmillan that he still wanted him to apply for membership of the Common Market, even if it meant an unconditional surrender. There were also brief discussions on Laos, Berlin and other foreign questions, after Mr. Kennedy had informed Mr. Macmillan of his discussions with Mr. Khrushchov. With the exception of 40 minutes when Lord Home, Foreign Secretary, and Mr. McGeorge Bundy, the President's special assistant for security affairs, were brought in, the two men talked alone.







Knowledge Base

Harold Macmillan Q128985 British politician and Prime Minister (1894–1986) 	Berlin Q64 Federal state, capital and largest city of Germany 
John F. Kennedy Q9696 35th president of the United States (1917–1963) 	Nikita Khrushchey Q35314 Soviet politician, First Secretary of the Communist Party of the Soviet Union (1894–1971) 
European Economic Community Q52847 International economic organization, 1958–1993 	McGeorge Bundy Q1575845 American National Security Advisor (1919–1996) 
Laos Q819 Sovereign state in Southeast Asia 	...

Motivation

Mr. **Kennedy** told Mr. **Macmillan** that he still wanted him to apply for membership of the **Common** **Market** even if it meant an unconditional surrender. There were also brief discussions on **Laos** **Berlin** and other foreign questions, after Mr. **Kennedy** had informed Mr. **Macmillan** of his discussions with Mr. **Khrushchov**. With the exception of 40 minutes when Lord Home, Foreign Secretary, and Mr. **McGeorge Bundy**, the President's special assistant for security affairs, were brought in, the two men talked alone.

Knowledge Base

<p>Harold Macmillan Q128985</p> <p>British politician and Prime Minister (1894–1986)</p> 	<p>Berlin Q64</p> <p>Federal state, capital and largest city of Germany</p> 
<p>John F. Kennedy Q9696</p> <p>35th president of the United States (1917–1963)</p> 	<p>Nikita Khrushchey Q35314</p> <p>Soviet politician, First Secretary of the Communist Party of the Soviet Union (1894–1971)</p> 
<p>European Economic Community Q52847</p> <p>International economic organization, 1958–1993</p> 	<p>McGeorge Bundy Q1575845</p> <p>American National Security Advisor (1919–1996)</p> 
<p>Laos Q819</p> <p>Sovereign state in Southeast Asia</p> 	<p>...</p>

Example





Many places and monuments have been named in honour of Washington, most notably the capital of the United States, Washington, D.C. In addition, Washington is the only US state named after a president.

1.Step: Mention Detection

Many places and monuments have been named in honour of **Washington** PERSON ,
most notably the capital of the **United States** LOCATION , **Washington, D.C.** LOCATION
In addition, **Washington** LOCATION is the only **US** LOCATION state named after a president.

2.Step: Candidate Selection

Candidate list

<u>George Washington</u> 1st president of the United States (1732-1799) 	Q23	<u>Harold Washington</u> American politician, former Mayor of the city of Chicago (1922-1987) 	Q295584	<u>Walter Washington</u> American politician and former mayor of the District of Columbia (1915-2003) 	Q935067	<u>Conor Washington</u> Association football player 	Q16235149
---	-----	---	---------	---	---------	---	-----------

Many places and monuments have been named in honour of **Washington** PERSON ,
most notably the capital of the **United States** LOCATION , **Washington, D.C.** LOCATION
In addition, **Washington** LOCATION is the only **US** LOCATION state named after a president.

3.Step: Entity Ranking

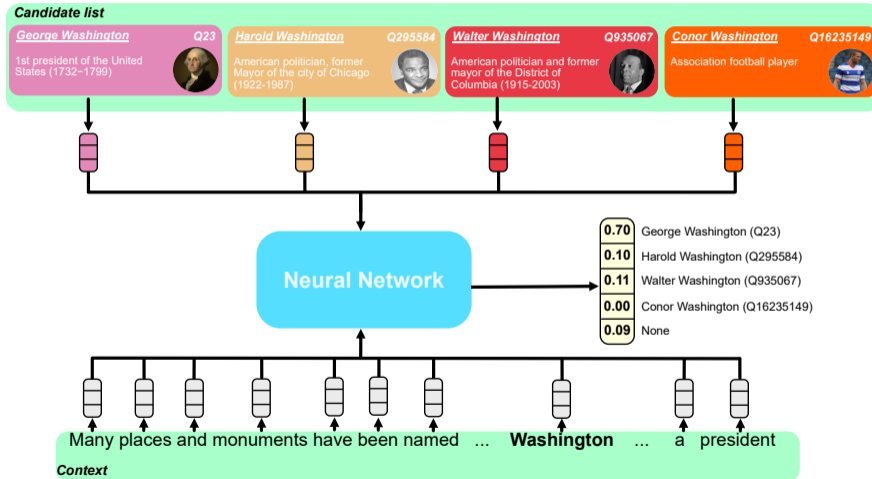

Datasets

Rare Hendrix song draft sells for almost \$ 17,000 .
 LONDON 1996-08-22 A rare early handwritten draft of a song by U.S. guitar legend Jimi Hendrix was sold for almost \$ 17,000 on Thursday at an auction of some of the late musician 's favourite possessions . A Florida restaurant paid 10,925 pounds (\$ 16,935) for the draft of " Ai nil no telling " , which Hendrix penned on a piece of London hotel stationery in late 1966 . At the end of a January 1967 concert in the English city of Nottingham he threw the sheet of paper into the audience , where it was retrieved by a fan . Buyers also snapped up 16 other items that were put up for auction by Hendrix 's former girlfriend Kathy Eltringham , who lived with him from 1966 to 1969 . They included a black lacquer and mother of pearl inlaid box used by Hendrix to store his drugs , which an anonymous Australian purchaser bought for 5,060 pounds (\$ 7,845) . The guitarist died of a drugs overdose in 1970 aged 27 .

(a) HW-AIDA-CoNLL

Sentence Database	P03-080
"Gubbins? Gubbins!" he fretted. "Who's he?" Though Diana knew the names of every member of the staff, distinguished or not, Nigel often had to think hard to sort them out. "He's the carrotty lad, isn't he?" he now demanded. "What was he doing at the Load of Trouble?"	
"Gubbins? Gubbins?" he fretted. "Who's he?" Though Diana knew the name of every member of the staff, distinguished or not, Nigel often had to think hard to sort them out. "He's the carrotty lad, isn't he" he now demanded. "What was he doing at the load of Trouble?"	

(b) IAM-DB

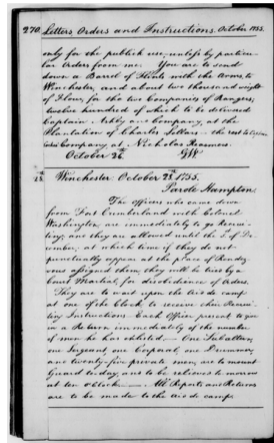

(c) George Washington

HW-AIDA-CoNLL

Rare Hendrix song draft sells for almost \$ 17,000 .
 LQADQN 1996-08-22 A rare early handwritten draft of
 a song by U.S. guitar legend Jimi Hendrix was sold
 for almost \$ 17,000 on Thursday at an auction of some
 of the late musician 's favourite possessions . A Florida
 restaurant paid 10,925 pounds (\$ 16,935) for the draft
 of " Ai nil no telling " , which Hendrix penned on a
 piece of London hotel stationery in late 1966 . At the
 end of a January 1967 concert in the English city of
 Nottingham he throw the sheet of paper into the
 audience , where it was retrieved by a fan . Buyers
 also snapped up 16 other items that were put up for
 auction by Hendrix 's former girlfriend Kathy
 Elchingham , who lived with him from 1966 to 1969 .
 They included a black lacquer and mother of pearl
 inlaid box used by Hendrix to store his drugs , which
 an anonymous Australian purchaser bought for 5,060
 pounds (\$ 7,845) . The guitarist died of a drugs
 overdose in 1970 aged 27 .

 300+

real 110

 English

 46448



 WIKIDATA

 modern

test AIDA-B, MSNBC, WIKI, CWEB

IAM-DB

"Gubbins? Gubbins?" he fretted. "Who's he?"
 Though Diana knew the name of every
 member of the staff, distinguished or not,
 Nigel often had to think hard to sort
 them out. "He's the carrotty lot, isn't he
 he now demanotted." What was he
 doing at the load of Trouble?



George Washington

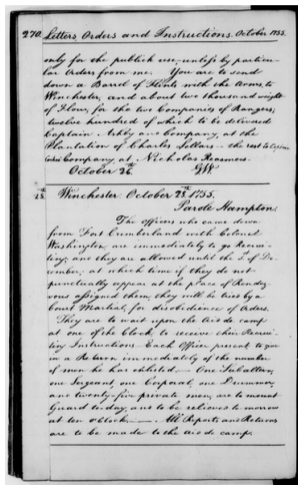

Baseline Approach

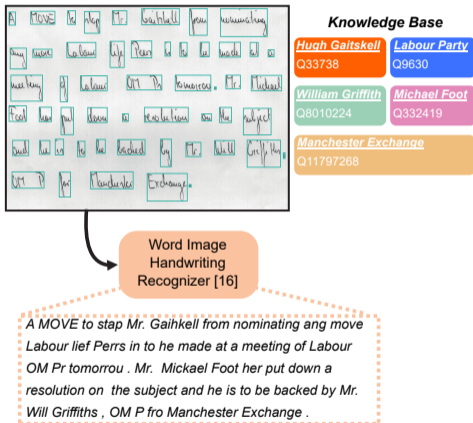

[16] L. KANG, J. I. TOLEDO, P. RIBA, M. VILLEGAS, A. FORNÉS . M. RUSIÑOL: *Convolve, Attend and Spell: An Attention-based Sequence-to-Sequence Model for Handwritten Word Recognition.* . Proc. German Conf. on Pattern Recognition, . 459–472, Stuttgart, Germany, 2018

Baseline Approach

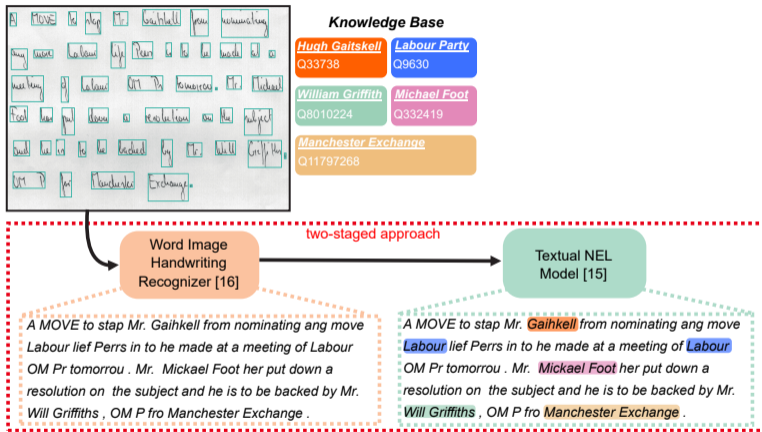

[16] L. KANG, J. I. TOLEDO, P. RIBA, M. VILLEGAS, A. FORNÉS . M. RUSIÑOL: *Convolve, Attend and Spell: An Attention-based Sequence-to-Sequence Model for Handwritten Word Recognition*. . *Proc. German Conf. on Pattern Recognition*, . 459–472, Stuttgart, Germany, 2018

[15] J. M. VAN HULST, F. HASIBI, K. DERCKSEN, K. BALOG . A. P. DE VRIES: *REL: An Entity Linker Standing on the Shoulders of Giants*. . *Proc. Int. ACM SIGIR Conf. on Research and Development in Information Retrieval*, . 2197–2200, Xi'an, China, 2020

Baseline Approach

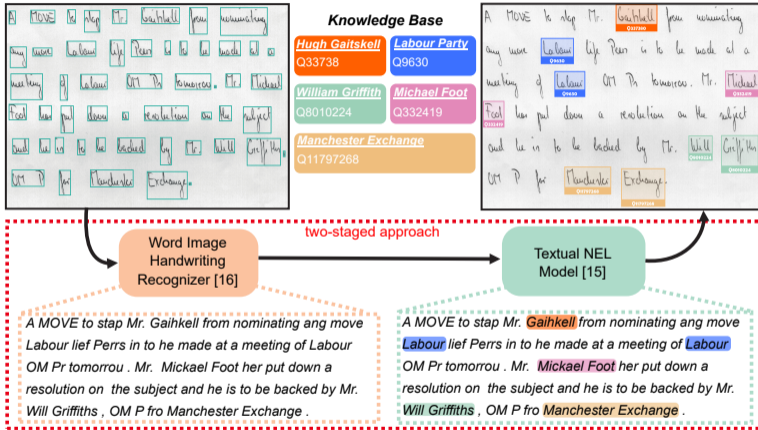

[16] L. KANG, J. I. TOLEDO, P. RIBA, M. VILLEGAS, A. FORNÉS . M. RUSIÑOL: *Convolve, Attend and Spell: An Attention-based Sequence-to-Sequence Model for Handwritten Word Recognition*. . *Proc. German Conf. on Pattern Recognition*, . 459–472, Stuttgart, Germany, 2018

[15] J. M. VAN HULST, F. HASIBI, K. DERCKSEN, K. BALOG . A. P. DE VRIES: *REL: An Entity Linker Standing on the Shoulders of Giants*. . *Proc. Int. ACM SIGIR Conf. on Research and Development in Information Retrieval*, . 2197–2200, Xi'an, China, 2020

Handwriting Text Recognizer

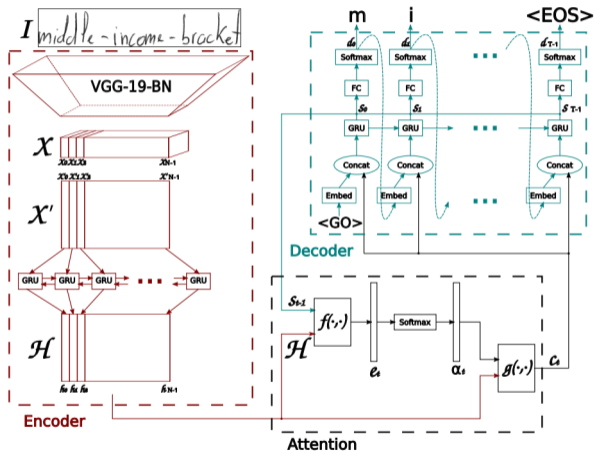

[1] L. KANG, J. I. TOLEDO, P. RIBA, M. VILLEGAS, A. FORNÉS . M. RUSIÑOL: *Conville, Attend and Spell: An Attention-based Sequence-to-Sequence Model for Handwritten Word Recognition.* . Proc. German Conf. on Pattern Recognition, . 459–472, Stuttgart, Germany, 2018

REL: Radbound Entity Linker

Mention Detection

Candidate Selection

Entity Ranking

REL: Radboud Entity Linker

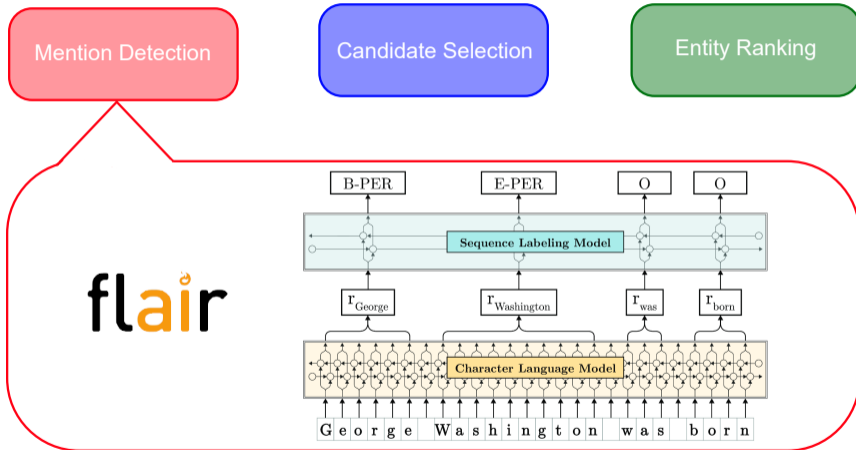

[1] A. AKBIK, T. BERGMANN, D. BLYTHE, K. RASUL, S. SCHWETER, R. VOLLGRAF: *FLAIR: An Easy-to-Use Framework for State-of-the-Art NLP*. . Annual Conf. of the North American Chapter of the Association for Computational Linguistics, . 54–59, Minneapolis, MN, USA, 2019

REL: Radbound Entity Linker

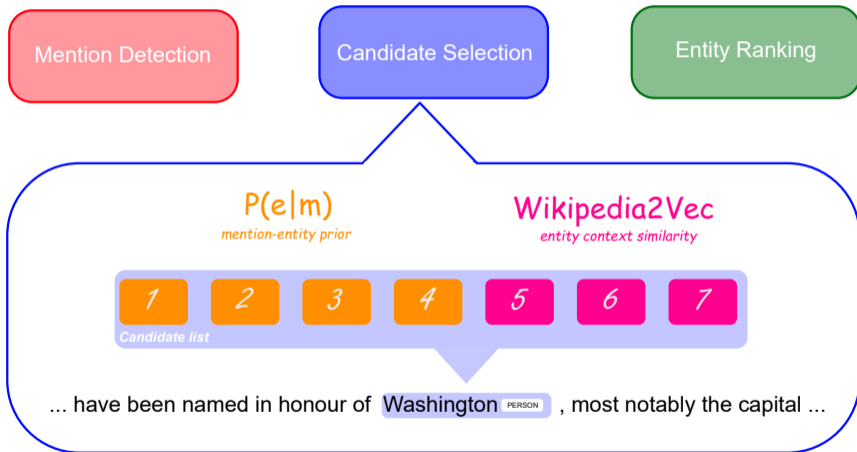

[1] O. GANEA . T. HOFMANN: *Deep Joint Entity Disambiguation with Local Neural Attention*. . *Proc. Conf. on Empirical Methods in Natural Language Processing*, . 2619–2629, Copenhagen, Denmark, 2017

REL: Radbound Entity Linker

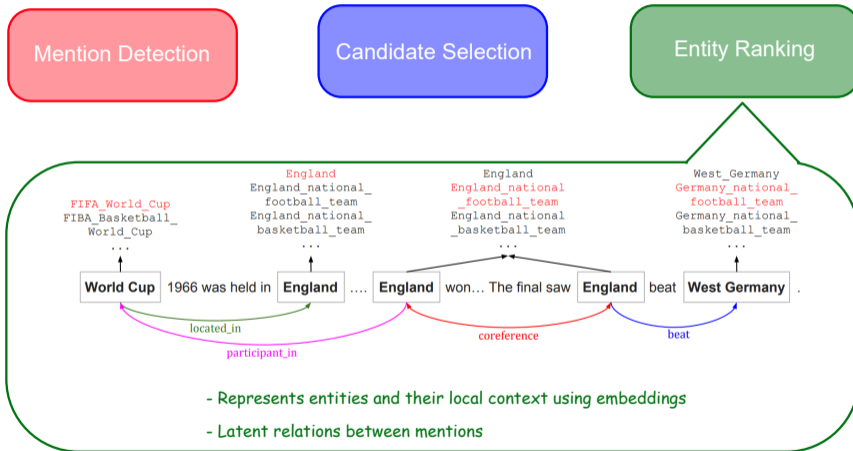

[1] P. LE . I. TITOV: *Improving Entity Linking by Modeling Latent Relations between Mentions*. . *Annual Meeting of the Association for Computational Linguistics*, . 1595–1604, Melbourne, Australia, 2018

REL: Radbound Entity Linker

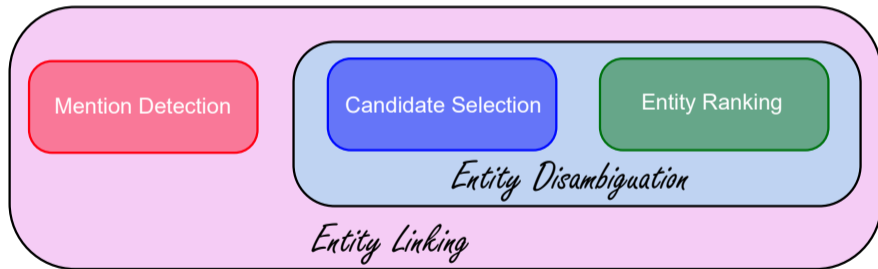

Evaluation metric

$$Precision = \frac{\# \text{ of correctly detected and disambiguated mentions}}{\# \text{ of predicted mentions by model}} \quad (1)$$

$$Recall = \frac{\# \text{ of correctly detected and disambiguated mentions}}{\# \text{ of mentions in gold standard}} \quad (2)$$

$$F1 = \frac{2 * Precision * Recall}{Precision + Recall} \quad (3)$$

InKB → only mentions that have an entity in KB or where NEL approach predicted an entity for

Strong annotation matching → mention has to be recognized completely and linked properly

Results

Table: Named Entity Disambiguation (NED) and Linking (NEL) performances measured in InKB micro F1 score based on strong annotation matching

		AIDA-B	MSNBC	WIKI	CWEB	IAM	GW
<i>NED</i>	<i>Annotation</i>	87.9	91.9	75.7	76.7	69.4	22.6
	<i>HTR+D</i>	74.8	80.1	63.1	60.1	54.9	19.4
	<i>HTR</i>	52.0	59.0	47.9	45.8	31.4	12.9
<i>NEL</i>	<i>Annotation</i>	79.1	75.4	40.1	47.8	49.8	15.2
	<i>HTR+D</i>	68.0	64.2	33.2	34.9	38.1	12.5
	<i>HTR</i>	56.7	55.7	30.6	33.8	27.5	7.1

